



29908

## 1956-62 Trunk Mats

- Reproductions Of Original

A1815B



29908	1956-57 Black	▲▲	259.99 ea.
29907	1956-57 Red	▲▲	259.99 ea.
29910	1958 Red	▲▲	299.99 ea.
29911	1958 Black	▲▲	299.99 ea.
A1816B	1959 Black w/o Power Top	▲▲	345.99 ea.
48269	1959 Blue w/o Power Top	▲▲	319.99 ea.
48270	1959 Turquoise w/o Power Top	▲▲	259.99 ea.
A1816A	1959 Red	▲▲	299.99 ea.
48272	1960 Turquoise w/Power Top	▲▲	299.99 ea.
48271	1960 Blue w/Power Top	▲▲	299.99 ea.
29914	1960 Black w/Power Top	▲▲	345.99 ea.
29913	1960 Red w/Power Top	▲▲	319.99 ea.
48268	1958 Blue	▲▲	259.99 ea.
A1815B	1961-62 Black	▲▲	319.99 ea.
29929	1961 Jewel Blue	▲▲	299.99 ea.
29928	1961-62 Fawn Beige	▲▲	299.99 ea.



## 1956-62 Molded Trunkliners

- Paint As Required

29798	1956 All (Molded)	▲	159.99 ea.
29798	1957 Without Power Top (Molded)	▲	159.99 ea.
29799	1958-60E Without Power Top (Molded)	▲	159.99 ea.
29800	1957-60 With Power Top (Molded)	▲	189.99 ea.
29802	1961-62 With Power Top (Molded)	▲	149.99 ea.



46091

## 1958-62 Flat Trunkliners

- Paint As Required

A1811	1958-60 Black Flat	49.99 ea.
46091	1958-60E Red Flat	49.99 ea.
A1812	1961-62 Black Flat	49.99 ea.
46092	1961-62 Red Flat	49.99 ea.

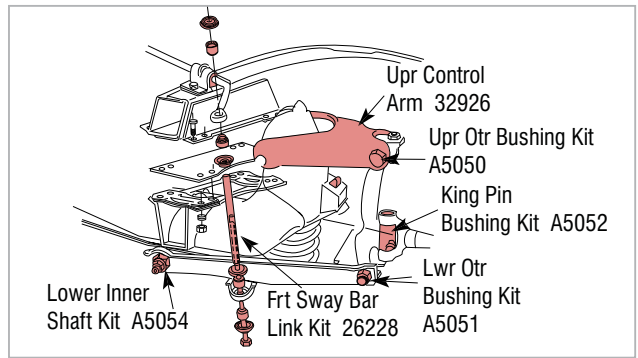

## 1953-62 Front Upper Control Arm

- Reproduction Of Original
- Manufacturer's Limited Lifetime Warranty

32926 179.99 ea.



## 1953-62 Steering Knuckle Upper Pinch Bolt Kit

- Reproduction Of Original

41547 (2 Req. Per Car) 5.99 kit

## 1953-62 Inner Tower Upper Control Arm Bushings

- Reproductions Of Original

22500



41.99 pr.

## 1953-62 Lower Control Arm Outer Bushing Kit

- Made In U.S.A.
- Outperforms Budget Imports
- Includes Jam Nut Unlike Budget Imports
- Manufacturer's Limited Lifetime Warranty

A5051

99.99 kit



## 1953-62 Upper & Lower Control Arm Bumpers

- Reproductions Of Original
- Set Of Four

A7260

54.99 set



## 1953-62 Upper Control Arm Outer Bushing Kit

- Reproductions Of Original

A5050 54.99 kit

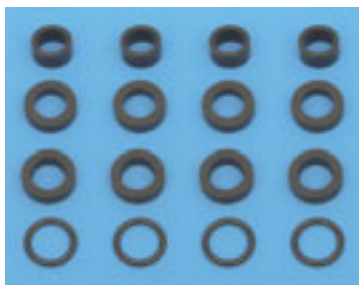

## 1953-62 Front Suspension Shaft Seal Kit

- Reproduction Of Original
- Completes Upper & Lower Shafts

41548 43.99 kit

## 1953-62 Zerk Covers

Keep dirt where it belongs - out of your suspension - with plastic zerk covers.

A7110 (12 pc.) 3.99 kit

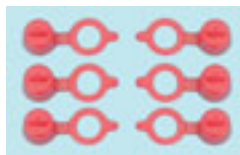

A5052

## 1953-62 King Pin Bushing Set

- Manufacturer's Limited Lifetime Warranty

A5052 65.99 set



A5058



A5054



41593



A5053

## 1953-62 Front Suspension Hardware

- Reproduction Of Original

A5058	1953-62 Lower Shock Bracket	19.99 ea.
41547	1953-62 Upper Outer Shaft Bolt Kit	5.99 kit
41536	1953-62 Lower Outer Jam Nut	12.99 ea.
A5054	1953-62 Lower Control Arm Inner Shaft Kit	99.99 kit
A5053	1953-62 Upper Control Arm Inner Shaft Kit	59.99 kit
41593	1956-62 Aluminum Front Suspension Shim	19.99 ea.



41547

41536

## 1953-62 Front Coil Springs

- Stock Replacements For Standard Suspension
- Restores Original Ride Height & Original Ride Quality

40709 87.99 pr.

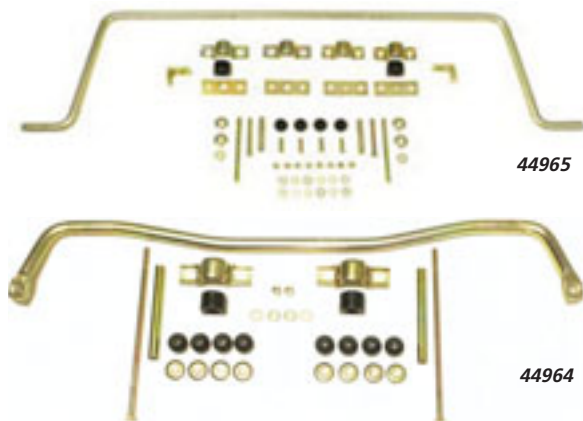

44965

44964

## 1953-62 Hi-Performance Sway Bar Kits

- Upgrade Over Factory Bar
- Reduces Unwanted Body Roll

At 7/8" this bar is properly sized to provide an immediate, recognizable improvement over the smaller sized factory bar. It also has urethane center and end link bushings to provide instantaneous sway bar response. The kit includes the bar, bushings and all necessary mounting hardware.

44964 Front 149.99 kit 44965 Rear 139.99 kit



26228



22595

## 1953-62 Sway Bar Hardware

46271	1953-62 Front Sway Bar Bracket	12.99 ea.
46270	1953-62 Front Sway Bar Bracket Spacer	8.99 ea.
26228	1953-62 Front Sway Bar, Link Kit	34.99 kit
22595	1957-59 Front Sway Bar Bushing w/ HD Suspension	18.99 ea.
22595	1960-62 Front Sway Bar Bushing	18.99 ea.

## 1956-62 Rear Leaf Spring Lower Mounting Plate

46287	1956-59 Left	61.99 ea.
46288	1956-59 Right	61.99 ea.
46289	1960-62 Left	61.99 ea.
46290	1960-62 Right	61.99 ea.



46288

## 1953-62 Rear Leaf Spring Front Mounting Bushing Kit

- Reproductions Of Original

A7209 39.99 kit



A7209

## 1953-62 Rear Spring Shackle

- Reproductions Of Original

A7200 29.99 kit  
55025 Kit Includes (2) Shackles 89.99 kit



A7200

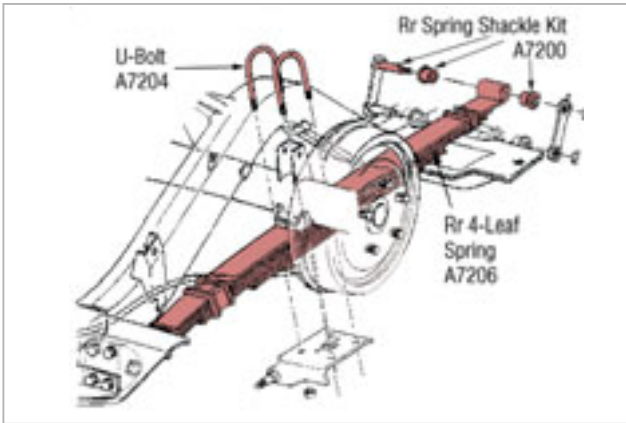

## 1953-62 Rear Leaf Springs

A7206	110 lbs. (4 Leaf Design)	149.99 ea.
A7205	145 lbs. (5 Leaf Design)	159.99 ea.

## Rear Spring U-Bolt & Front Saddles

- Reproduction Of Originals



A7204	1956-62 U-Bolt	10.99 ea.
46285	1953-62 Front Saddle, Left	55.99 ea.
46286	1953-62 Front Saddle, Right	55.99 ea.

## 1956-62 Rear Suspension Hardware



A7219	1957-58 Bumper, Rear Axle, Frame	25.99 ea.
A7220	1959-61 Bumper, Rear Axle, Frame	24.99 ea.
A7220	1962 Bumper, Rear Axle, Frame Except HD Suspension	24.99 ea.
27339	1956-62 Washer, Shock Lower Cupped	2.99 ea.

## 1953-62 Rear Sway Bar End Link Kit

- Reproduction Of Original
- Kit Includes Bolts, Spacers, Grommets, Washers & Nuts
- One Kit Completes Left & Right Sides



45018		21.99 kit
-------	--	-----------



## 1960-62 Rear Sway Bar Bracket Spacer

- Reproduction Of Original

46283	2 Required	7.99 ea.
-------	------------	----------

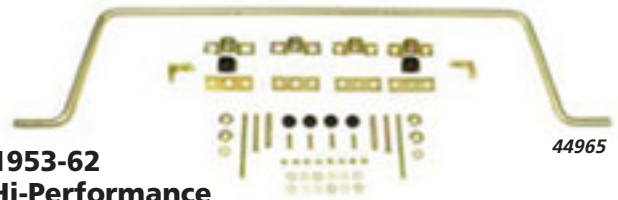

## 1953-62 Hi-Performance Rear Sway Bar Kit

- Upgrade Size For Corvettes With Stock Bars
- Excellent Addition for Corvettes Without Factory Rear Bar • Reduces Body Roll

This kit is ideal for improving the handling of Corvettes with factory equipped bars and an excellent addition for Corvettes which were not equipped with a factory bar. The 3/4" size rear bar is perfect for hi-performance street handling and the supplied urethane center bushings and end link bushings provide instantaneous sway bar response.

44965		139.99 kit
-------	--	------------

## 1960-62 Sway Bar Bushings

- Rubber Or Polyurethane

22608	Rubber 5/8" Rear	19.99 pr.
A7263	Polyurethane 5/8" Rear	25.99 pr.
A7262	Polyurethane 13/16" Front	29.99 pr.



## 1960-62 Rear Sway Bar Brackets And Bushings

- Reproduction Of Originals

46273	Inner Bracket	12.99 ea.
46272	Outer Bracket	10.99 ea.
46284	Frame Bracket	13.99 ea.



## 1959-62 Original Style Rear Strut Rod

- Reproductions Of Original

38612		69.99 ea.
-------	--	-----------



## 1959-62 Rear Strut Rod Bushing

- Reproduction Of Original

32761		13.99 ea.
-------	--	-----------

## 1956-62 New Driveshaft With U-Joints

- Replacement Driveshaft
- 2.5" Diameter

46099	169.99 ea.
-------	------------



## 1953-62 Differential/Transmission Vent

- Replacement

55363		22.99 ea.
-------	--	-----------

**NEW**





A7141



A7172

## 1953-62 Driveshaft U-Joint & U-Bolt

A7141 Driveshaft With 4 Speed 16.99 ea.

A7172 1953-62 Drive Shaft U-Bolt Kit (5 pc.) 9.99 kit

See Tools For U-Joint Removal

## 1956-62 Driveshaft Slip Yoke For Cars With Borg-Warner Transmission

- Reproduction Of Original

52891 1956-61 16 Spline† 109.99 ea.

52892 1956-62 27 Spline-6.0" Long \* 99.99 ea.

\* Borg-Warner T10 Or Muncie Transmission

† Replaces GM #3712379



52891

## 1953-62 Rear Axle Rebound Strap Kits

- Reproduction Of Original
- Completes One Car
- 27.24" Strap Length

47756 1953-58 79.99 kit

47757 1959 79.99 kit

47758 1960E 69.99 kit

47759 1960L-62 79.99 kit

A2253 1953-62 Retainers Only 12.99 kit

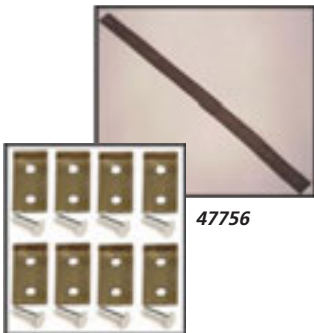

47756

## 1955-62 Ratio Ring & Pinion Gear Sets

- Replacement Set
- Matched Set

53830 3.55 Ratio 369.99 set

53831 3.98 Ratio 479.99 set

53832 3.73 Ratio 319.99 set

53833 4.11 Ratio 319.99 set



53833

## 1955-62 Differential Positraction Case With Spider Gears

- Replacement Case & Spider Gears (Ring & Pinion Not Included)

- Includes Spider Gears, Discs, Springs, Pole & Retainers

48818 599.99 ea.

See Page 95 For Differential Fluid & Additive



## 1955-62 Rear Differential Rebuild Kit

- Replacement Kit
- Includes Carrier Bearings & Races, Ring Gear Bolts, Front & Rear Pinion Bearing, Companion Flange (Pinion) Seal, Marking Compound & Brush, Crush Sleeve & Gasket

48800

139.99 kit

## 1957-62 Differential Pinion Flange

- Reproduction Of Original
- Replaces GM #3741822
- 17 Spline

54882

149.99 ea.



## 1955-62 Pinion Shaft & Gear Set

- Replacement Set
- Fits All Non-Posi Rear Ends
- Includes Both Axle Gears, Pinion Gears, Pinion Shaft, Shims & Washers

53829

269.99 set

## 1953-62 ACDelco "Reactek" Gas Cushioned Shock Absorbers

- Smooth Riding

These shocks can be used on all 1953-62 Corvettes either as a replacement for the standard equipment or heavy-duty AC Delco-Bilstein shock. The "Reactek" gives you a gas cushioned ride and has been designed to compensate for normal suspension fatigue that occurs in all Corvettes. Can not shipped by air.

20415 1953-62 Front 44.99 ea.

20416 1953-59 Rear 34.99 ea.

42049 1960-62 Rear 44.99 ea.

55985 1953-59 Front/Rear 159.99 set

55986 1960-62 Front/Rear 159.99 set



20416

42049

## 1953-62 KYB Gas Shock Absorber

- Great Performance • Great Price
- Excellent Replacement Shock

KYB high-pressure gas shocks are excellent high performance replacements for 1953-62 Corvettes. In terms of performance, KYB's are "guaranteed" not to fade! In fact, regardless of how much or how hard the shock is worked the KYB shock still provides 100% shock absorbing efficiency - now and forever. The KYB mono-tube shock is backed by a limited lifetime warranty. KYB is an excellent selection for Corvette owners who demand life-long service out of a performance shock.

44918 Front 49.99 ea. 44919 Rear 51.99 ea.

Can not be shipped by air.

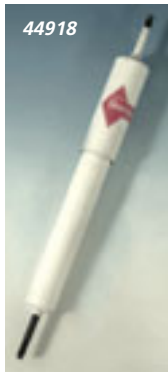

## 1953-62 Steering Gear Rebuild Kit

- Reproductions Of Original

48829 107.99 kit



## 1953-62 Third Arm Bearing & Hardware

20413 Bearing 35.99 ea.  
28831 Bearing Snap Ring 9.99 ea.  
22613 Seal 4.99 ea.



## 1953-62 Drag Link Seal & Repair Kit

22524 Seal (Urethane) 15.99 ea.  
34698 Repair Kit \* 149.99 kit

\* Manufacturer's Limited Lifetime Warranty



## 1953-62 Tie Rod End Sleeve & End Clamps

- Replacement

28709 Tie Rod End Sleeves 31.99 ea.  
50133 Clamps 2 Per Sleeve 14.99 pr.



## 1953-62 Left & Right Tie Rod Ends

- Replaces Worn Ends To Restore Front End Steering Control

44579 Left & Right 39.99 pr.  
A7196 Right 24.99 ea.  
A7197 Left 24.99 ea.



## 1958-62 Steeroids Rack & Pinion Conversion Kits

- Completely Bolt-On
- Tighter, More Responsive Steering
- Adjustable Tie Rod Ends To Eliminate Bump Steer



Ecklers is announcing the NEW Steeroids™ Rack and Pinion steering conversion kit for '53-'62 Corvettes which will update the 1940's steering design on these classics to 21st century standards. This is a true bolt-on kit, something never offered on C1's from the factory! Steeroids™ do not require any drilling, cutting or welding on the vehicle. Tighter, more responsive steering feel and lighter weight are all advantages to this system. Steeroids™ rack and pinion kits include an exciting quick ratio rack yielding approximately 2.5 turns lock-to-lock at the wheel. Steeroids kits also include adjustable tie rod ends to effectively eliminate bump steer so that your car not only steers better, it actually handles better! Steeroids™ kits are completely bolt-on so an owner can return to the stock steering at any time, but why would they?

### With Manual Steering

55539 With Chrome Column 2099.99 kit  
55537 With Black Powder Coated Column 2099.99 kit  
55535 With Unpainted Column 1899.99 kit

### With Power Steering

55538 Kit With Chrome Column 2199.99 kit  
55536 With Black Powder Coated Column 2199.99 kit  
55534 With Unpainted Column 2099.99 kit